

Additional Relay Installation for Compressor

Added

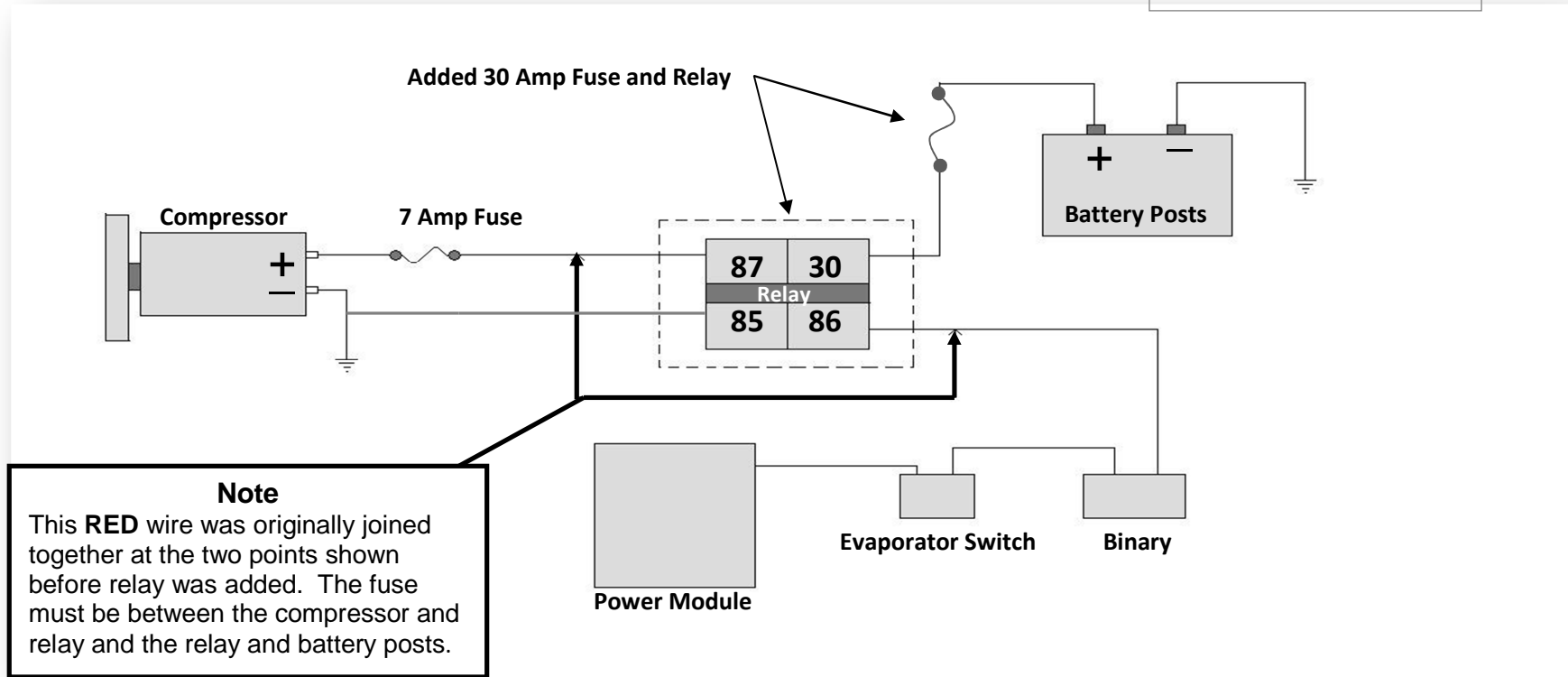

Wire Colours

- Compressor = Red
- Pin 30 = Red (battery)
- Pin 87 = Yellow (compressor)
- Pin 86 = Yellow (binary switch)
- Pin 85 = Black (chassis ground)

NOTE

PINS 30 AND 87 ARE THE POWER SWITCH WHILE PINS 85 AND 86 ARE THE RELAY TRIGGER.